

Compact Multidimensional Broadband Wireless: The Convergence of Wireless Mobile and Access

Willie W. Lu, Siemens AG

ABSTRACT

Broadband wireless communications have gained increased interest during the last few years. This has been fueled by a large demand on high-frequency utilization as well as a large number of users requiring simultaneous high-data-rate access for the applications of wireless mobile Internet and e-commerce. The convergence of wireless mobile and access will be the next storm in wireless communications, which will use a new network architecture to deliver broadband services in a more generic configuration to wireless customers, and support value-added services and emerging interactive multimedia communications. Large bandwidth, guaranteed quality of service, and ease of deployment coupled with recent great advancements in semiconductor technologies make this converged wireless system a very attractive solution for broadband service delivery.

INTRODUCTION

“The future of wireless is not just wireless, it is a part of life.” When we look back to the 1980s, everyone dreamed of having a nice mobile phone. But if we dream of the wireless picture in 2010, the story will be totally different. Why? Because at that time, the wireless infrastructure (not just for communications) will be totally multidimensional, whether in technologies

(diversified and harmonized), applications (free mobile, local or global), or services (service/bandwidth on demand). Our wireless personal communicator or assistant (the size of a wallet or up to a book with enough bandwidth and memory) can help us enjoy our lives. Wireless becomes easy and affordable in the mass market, even when you are away from your office; your business will never be offline. Global roaming and a high-speed wireless link (thanks to tremendous silicon advancements) will make our travels wonderful and make us feel at home anywhere.

The key applications evolved from the advancement of broadband wireless and the underlined technologies, including broadband wireless mobile (3Gwireless and 4Gmobile), broadband wireless access, broadband wireless networking, as well as broadband satellite solutions, will surely dominate the whole communications market and therefore improve the business model in many aspects.

Convergence of broadband wireless mobile and access will be the next storm in wireless communications. Fueled by many emerging technologies including digital signal processing, software-definable radio, intelligent antennas, superconductor devices, as well as digital transceivers, the future wireless system will be much more compact with limited hardware and more flexible and intelligent software elements. Reconfigurable and adaptive terminals and base stations help the system be easily applied in the wireless mobile as well as wireless access applications. The compact hardware and very small portion of software (called the *common air interface basic input-output system* or CAI BIOS) will go the way the computer industry did in the past. A compact multidimensional broadband wireless model will be adopted for system design and implementation.

Wireless mobile Internet will be the key application of this converged broadband wireless system. The terminal will be very smart instead of dumb, compatible with mobile and access services including wireless multicasting as well as wireless trunking. This new wireless terminal will



■ Figure 1. Convergence of wireless mobile and access in one track.

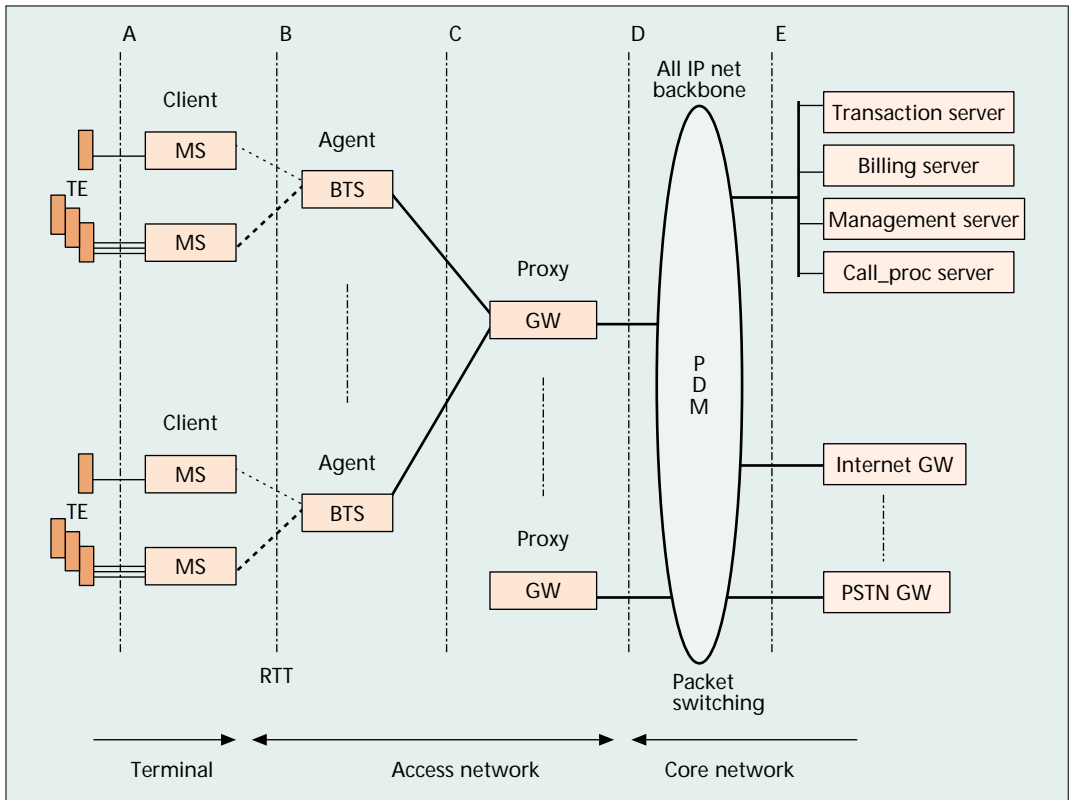

■ Figure 2. A network reference model.

have the following features:

- 90 percent of traffic will be data.
- The security function will be enhanced (e.g., fingerprint chip embedded).
- A voice recognition function will be enhanced; keypad or keyboard attachment will be an option, as will wirelessness.
- The terminal will support single and multiple users with various service options.
- The terminal will be fully adaptive and software-reconfigurable.

As wireless communications evolve to this convergence, fourth-generation mobile wireless communications (4Gmobile) will be an ideal mode to support high-data-rate connection from 2 to 20 Mb/s based on the new spectrum requirement for International Mobile Telecommunications 2000 (IMT-2000) as well as the coexistence of current spectrum for broadband wireless access. This 4Gmobile system's vision aims at:

- Providing a technological response to accelerated growth in demand for broadband wireless connectivity
- Ensuring seamless services provisioning across a multitude of wireless systems and networks, from private to public, from indoor to wide area
- Providing optimum delivery of the user's wanted service via the most appropriate network available
- Coping with the expected growth in Internet-based communications
- Opening new spectrum frontiers

Figure 1 shows the convergence of wireless mobile and access in one track, generating 4Gmobile. In the following sections we discuss

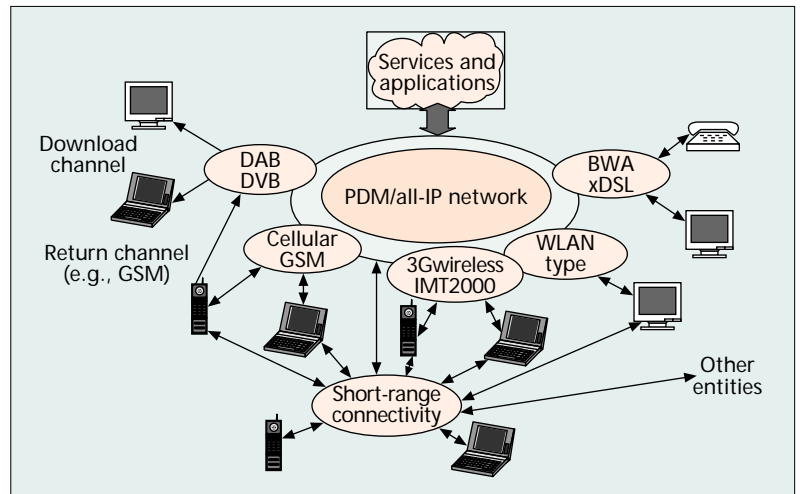

■ Figure 3. Unified wireless networks.

some detailed implementation issues, including system architecture, the reference model, and the protocol stack, as well as system design.

NETWORK ARCHITECTURE

The future wireless network should be an open platform supporting multicarrier, multibandwidth, and multistandard air interfaces, with content-oriented bandwidth-on-demand (BoD) services dominant throughout the whole network. In this way, packetized transmission will go all the way from one wireless end terminal directly to another. Figure 2 shows this new

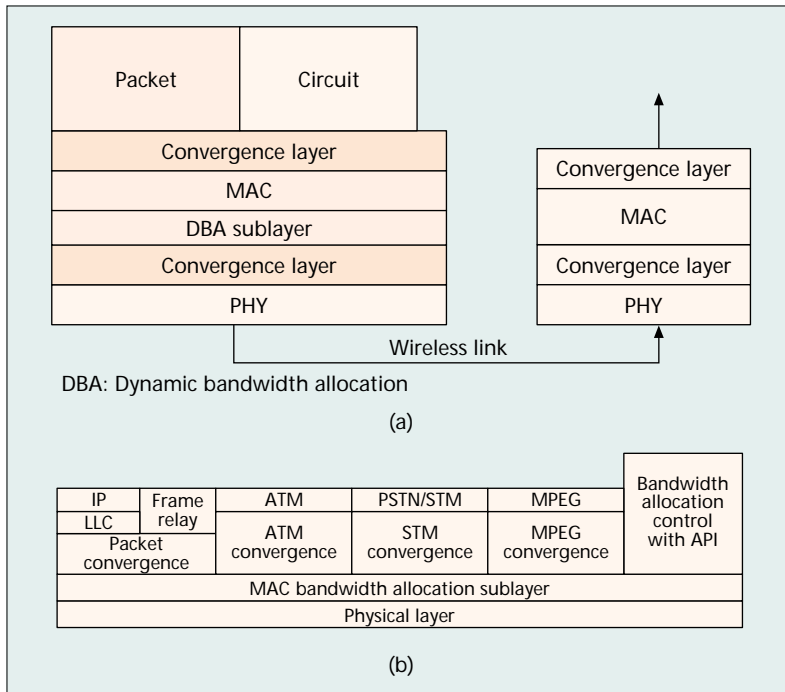

Figure 4. a) General protocol stack; b) protocol stack: examples.

wireless network architecture. The major benefits of this architecture are that the network design is simplified and the system cost greatly reduced. The base transceiver system (BTS) is now a smart open platform with a basic broadband hardware pipe embedded with a CAI BIOS. Most functional modules of the system are software-definable and reconfigurable. The packet switching is distributed in the broadband packet backbone (or core network, called *packet-division multiplex*, PDM). The wireless call processing, as well as other console processing, is handled in this network. The gateway (GW) acts as proxy for the core network and deals with any issues for the BTS, and the BTS is an open plat-

form supporting various standards, optimized for full harmonization and convergence. The terminal (mobile station, MS) can be single- or multi-user-oriented, supporting converged wireless applications. Figure 3 illustrates unified wireless networks based on this architecture [1].

THE PROTOCOL STACK

Considering the signaling protocol in Fig. 2, the client-server model is established between a wireless terminal and the core network. The BTS becomes the agent in both directions. This end-to-end direct signaling can ensure that the wireless terminal is smart and intelligent rather than the dumb one in the current wireless system. Figure 4a shows the system protocol stack.

Different services — asynchronous transfer mode (ATM), IP, synchronous transfer mode (STM), MPEG — can be supported through a service convergence layer. To guarantee wireless quality of service (QoS) and high spectrum utilization, dynamic bandwidth allocation (DBA) is required through the medium access control (MAC) DBA sublayer, which improves the conventional layer architecture. The DBA scheduler is the core of the MAC. To realize dynamic resource allocation, this scheduler is essential for the broadband wireless link, which in general helps:

- Support class of service offerings
- Provide agnostic support for all network protocols
- Eliminate the need for traffic shaping and user parameter control
- Eliminate end-to-end packet and/or cell delay variation
- Increase spectrum utilization

The transmission convergence layer handles various transmission modulations, error corrections, segmentations, and interface mappings of wireless mobile and access in the physical layer. Figure 4b shows an example of support for wireless access applications.

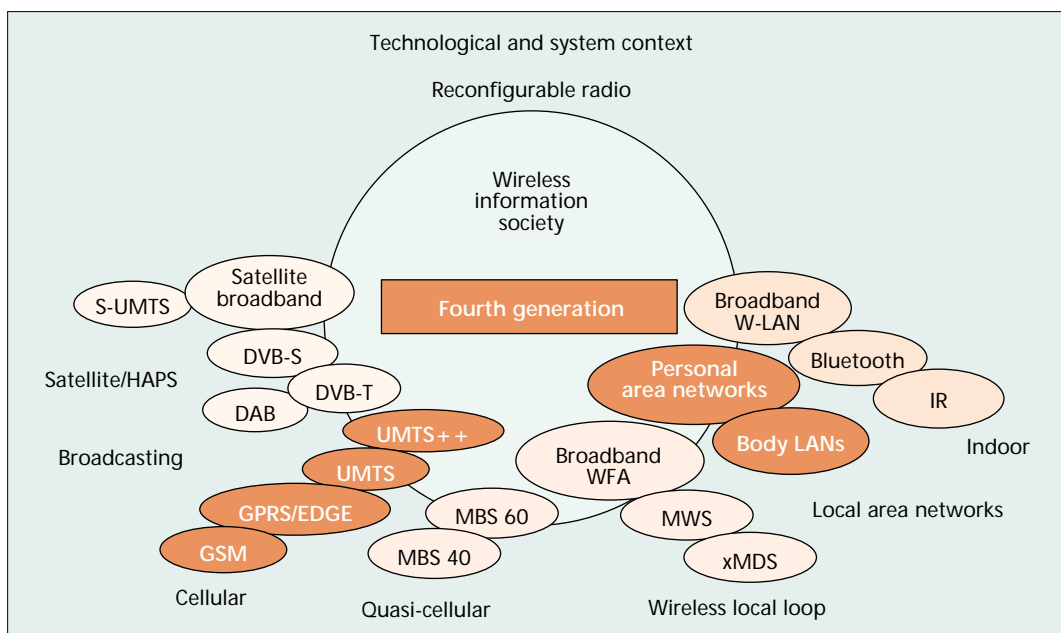

Figure 5. Multidimensional and reconfigurable radio.

COMPACT OPEN CORE

As mentioned in the previous sections, this converged broadband wireless system will have the following features:

- Multistandard: 3G wireless plus broadband wireless access
- High channel density with efficient resource utilization
- Dynamically scalable data rates: from 32 kb/s to 20 Mb/s
- Software-definable and over-the-air programmable modules
- Open core: various reconfigurable kernels and CAI BIOS

Figure 5 depicts this multidimensional and reconfigurable radio [1], while Fig. 6 shows its open interfaces. As wireless goes multidimensional, different standards come out every day for different applications. However, if you look at their architectures in detail, most of them are the same or almost same. The all-IP layer will become the common platform; the service will be based on the secure wireless mobile Internet; the convergence will focus on variable service demands as well as transmission technologies.

From the implementation point of view, in the future, the wireless software will take about 75 percent of the work, the hardware only 25 percent for the construction of the open platform. Figure 7 shows this basic hardware structure.

The digital block will eventually be implemented in one system, and further on one chip (system on a chip). The analog block leaves there as an open module subject to various CAI standards. With superconductivity technology advances, this block will probably become a separate analog header only. The broadband pipe throughout this hardware will be reconfigurable and adaptive. The CAI BIOS will be the software kernel to access and control the common hardware platform.

Figure 8 lists the major functions embedded in this compact hardware implementation, where minimum software control is required. There are four key modules in the systems: the air interface module, baseband processing unit, digital broadband transceiver, and smart antenna array. The detailed functional segments are required

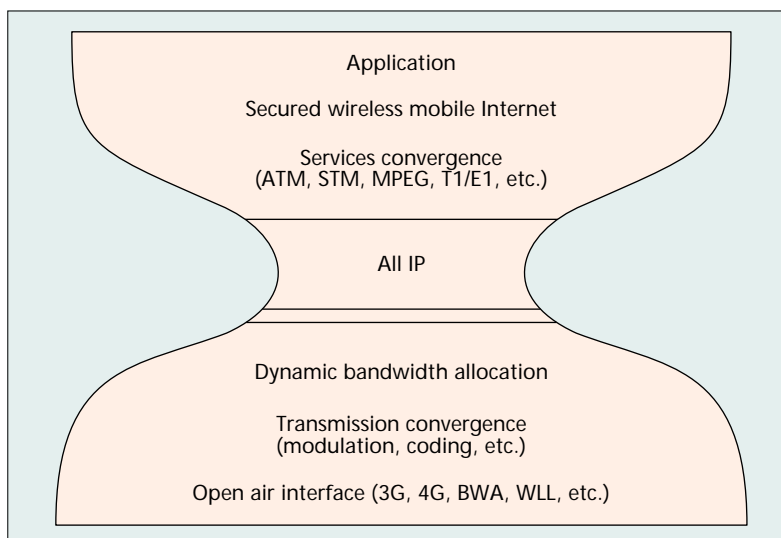

■ Figure 6. Compact broadband wireless — open interfaces.

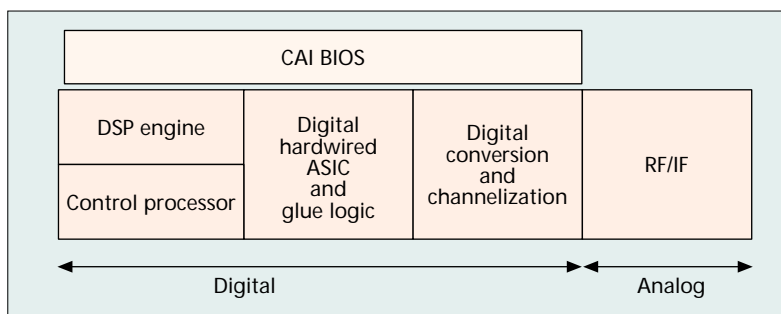

■ Figure 7. An open platform for broadband wireless mobile and access.

for the converged implementations of the proposed broadband wireless system.

As an example, Fig. 9 shows the open terminal architecture of this compact wireless system, where the DSP core, CAI BIOS and soft radio API, and main processor unit (MPU)/CPU are the three most important entities. The RF/IF subsystem is an independent unit configurable to different applications of wireless mobile or wireless access. The digital downconverter (DDC), digital upconverter (DUC), ADC, and DAC are

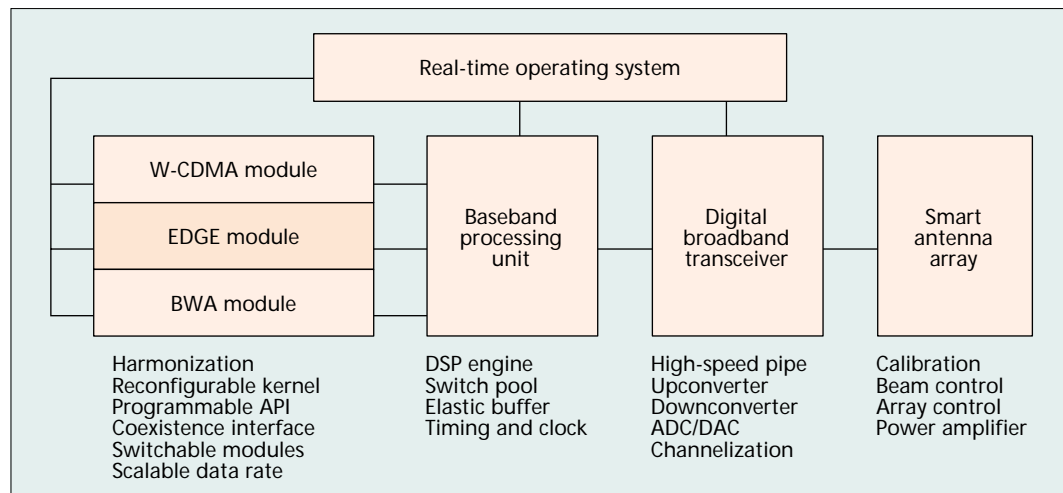

■ Figure 8. Functional segments of the converged broadband wireless systems.

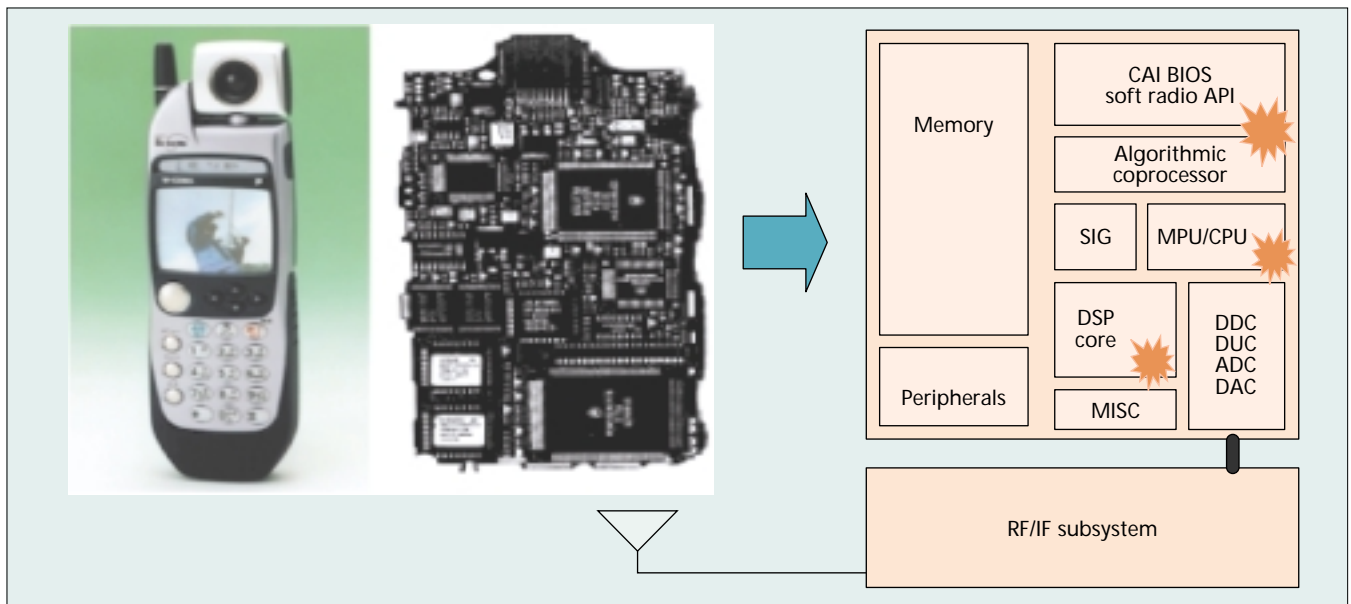

■ Figure 9. A compact wireless open terminal.

components of the broadband digital transceiver system. SIG handles various signaling protocol stacks (e.g., all-IP and IP on air).

The proposed 4Gmobile [1–3] will be an ideal model of this converged wireless mobile and access system. The 4Gmobile network and terminal reconfigurability (scalable and flexible, self-organized) includes:

- The adaptation of resource allocation to cope with varying traffic load, channel conditions, and service environments
- Integration of fixed/mobile/broadcasting networks and rules for distribution and decentralized control of functional entities
- Protocols that permit the network to adapt dynamically to changing channel conditions, and allow the coexistence of low- and high-rate users, handoff of high-data-rate users between base stations, congestion control algorithms that are cognizant of and adjust to changing channel conditions, and so on
- Development of system concepts for digital broadband millimeter wave capable of delivering higher bit rates for broadband wireless access applications

Therefore, 4Gmobile will provide seamless high-data-rate wireless service over an increasing number of integrated but distinct and heterogeneous wireless mobile and access platforms and networks operating across multiple frequency bands. This service adapts to multiple wireless standards (and multimode terminal capabilities) and delay-sensitive or -insensitive applications over radio channels of varying bandwidth, across multiple operators and service provider domains with fully user-controlled QoS levels.

CONCLUSIONS

In this article, a new compact multidimensional broadband wireless core is summarized with focus on the convergence of wireless mobile and access technologies. As the wireless industry booms in the coming years, this converged wireless system

will surely become the major player for wireless mobile Internet services and applications.

The International Telecommunications Union defined future wireless systems beyond 3Gwireless as 4Gmobile, which actually outlines the key features of our proposed convergence of broadband wireless mobile and access systems. 4Gmobile will present a beautiful wireless life in 2010, when wireless will not just be a technology.

ACKNOWLEDGMENTS

This article is based on my previous featured speech, “Multi-Dimensional Broadband Wireless,” at Stanford University, which attracted over 500 attendees from Silicon Valley. Many materials in the article are from the 3Gwireless 2000 proceedings by the Delson Group. Thanks should also be given to my colleagues in ITU WP8F, ITU JRG 8A-9B, and IEEE 802.16 for their encouragement and support.

REFERENCES

- [1] ITU 8F/INFO/4-E, “4Gmobile — Beyond IMT-2000,” Mar. 2000.
- [2] ITU 8F/INFO/1-E, “The 4Gmobile Systems,” Feb. 2000.
- [3] *Proc. IEEE 3Gwireless 2000*, San Francisco, CA, June 14–16, 2000.

ADDITIONAL READING

- [1] J. Hu, “Applying IP Over w ATM Technology to 3Gwireless,” *IEEE Commun. Mag.*, vol. 37, no. 11, Nov. 1999, pp. 64–67.
- [2] *IEEE Pers. Commun.*, Special Issue on 3Gwireless and Beyond, Oct. 2000.
- [3] W. W. Lu *et al.*, “System Reference Model and Protocol Stack for Broadband Wireless Access,” *Proc. IEEE ICC 2000*, New Orleans, LA, June 18–22, 2000, pp. 560–64.
- [4] While paper on broadband wireless access systems, <http://www.ieee802.org/16>

BIOGRAPHY

WILLIE W. LU [SM] (wwlu@ieee.org), principal senior wireless architect at Siemens-Infineon, has extensive research, publication, consulting, and industrial experience in the design and analysis of advanced wireless telecommunication systems and networks, computer communication sys-

tems, local, metropolitan, and wide area communications networks, marketing analysis, and planning. He has profound expertise in the implementation of software-definable base station technology, wireless mobile ATM technology, third-generation wireless communications, broadband wireless access, wireless mobile Internet, and high-speed packet networks as well as IP/ATM network interconnections. He is Chair of the Wireless Mobile ATM Task Force, CDMA Technical Forum, and 3Gwireless Technical Forum, technical teams of telecommunications and wireless communications experts who develop and implement next-generation wireless multimedia systems. Previously, he served as guest scientist at the German National Research Center for Information Technology (GMD), Berlin. His other work has involved the design of the U.S. CDMA system at Nortel and a wireless data network at NTT. He is highly accredited and an invited senior technical advisor by major telecom industries in the United States and Europe as well as a senior consultant to many telecom authorities in the world. He served as general chair of IEEE *wmATM '98*, *wmATM '99*, *3Gwireless 2000*, and *GLOBECOM 2000 Broadband Wireless and 3Gwireless 2001*. He was/is guest editor of special issues on *wmATM*, *BWA*, and *3Gwireless* technologies in several journals and publications. He is also a voting member of Sigma Xi, ACM, IEICE Japan, and CIC China. He is a Feature Editor of the Wireless Communications Series in *IEEE JSAC* and *IEEE Communications Magazine*, and has over 100 professional publications.